

Models A & B

mROY® series models A and B metering pumps are controlled-volume, hydraulically-actuated diaphragm pumps that are designed for consistent chemical delivery. Its compact design contains a plunger that reciprocates at a fixed stroke, displacing a fixed volume of hydraulic fluid and thereby actuating a flexible, chemically inert PTFE diaphragm to create the pumping action. This field-proven design enables metering with repetitive steady-state accuracy at a $\pm 1\%$ range. Designed to meet global industry standards, models A and B provide accurate dosing of a broad spectrum of fluids. Like all mROY® metering pumps, models A and B are built to run continually all year long with preventative maintenance, leading to decades of consistent performance.

Applications

Injection of chemicals such as coagulants, biocides, disinfectants, polymers, softening agents, acids and bases for pH control, scale and corrosion inhibitors, oxygen scavengers, process additives, and many more for the following areas of application:

- Chemical and petrochemical processing
- Cooling towers and boilers
- Drinking water treatment
- Oil and gas production
- Food and beverages industry
- Industrial water and wastewater treatment
- Pharmaceuticals production
- Power generation
- Agriculture

Features and Benefits

- Hydraulically-balanced PTFE diaphragm, designed for 96,000 hours operating life, does not use seals and eliminates plunger packing maintenance.
- Liquid end bleed system makes it easier to commission a new or a newly maintained pump.
- Worm and pinion drive operating in an oil bath lubrication produces a smooth mechanical motion that eliminates wear and tear of mechanical lost motion designs and assures long gear and bearing life.
- Dust-tight cast iron housing provides a rugged enclosure for operation in the harshest plant and field environments.
- Micrometer capacity adjustment enables accurate output flow control.
- Internal hydraulic pressure relief valve automatically protects the pump's hydraulic system from over pressure conditions.
- High-performance, adjustable, cartridge-type check valves provide positive, repeatable sealing on every pump stroke.
- Metallic and non-metallic liquid end materials, available for corrosion resistance in any chemical application.
- The pump is capable of withstanding a wide range of fluid and ambient temperatures with options for extreme low and high temperature requirements.
- Simplex and duplex versions available.
- The pump meets standards for CE, ATEX, and API 675.
- Extensive motor mount and pipe connection options are available for process compatibility and simple integration into chemical injection systems.
- Process compatibility options are easily selected such as heating/cooling liquid end jackets, configurations for slurries or viscous fluids, unique material combinations, etc.

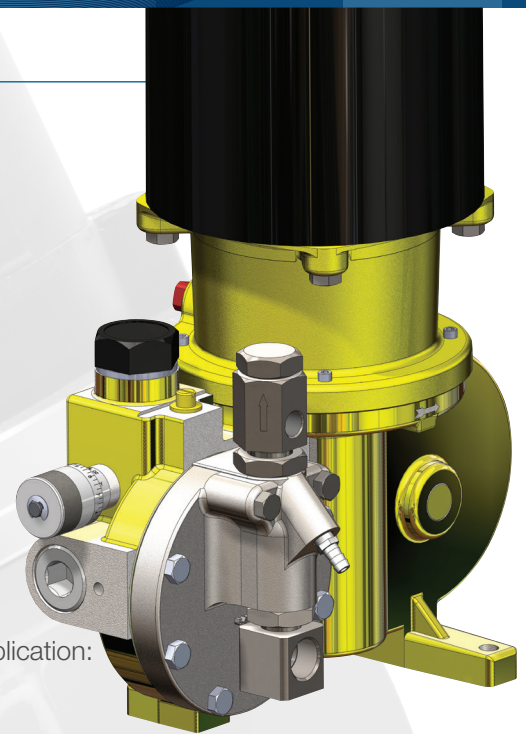

Maximum Capacity Ratings (@ 100 psi / 7 bar)		
Motor	gph	l/hr
50 hz - 1425 RPM	0.30 to 87.36	1.1 to 330.6
60 hz - 1725 RPM	0.36 to 85	1.4 to 321.7

General Specifications

mROY® Model A - Metallic Liquid Ends

mRoy Model	Plunger		Gear Ratio Code	Stroke/Minute		Capacity/Pressure @ 60 hz 1725 RPM						Capacity/Pressure @ 50 hz 1425 RPM					
	Diameter	Code		60 hz 1725 rpm	50 hz 1425 rpm	Ratings at 100 psi/7 bar		Capacity at Max pressure				Ratings at 100 psi/7 bar		Capacity at Max pressure			
						gph	l/hr	gph	l/hr	psi	bar	gph	l/hr	gph	l/hr	psi	bar
A	3/8 in 9.5 mm	C	77	23	19	0.36	1.4	0.20	0.8	2,000	137.9	0.30	1.1	0.17	0.6	2,000	137.9
			48	37	30	0.73	2.8	0.34	1.3	2,000	137.9	0.61	2.3	0.28	1.1	2,000	137.9
			24	73	60	1.44	5.5	0.68	2.6	2,000	137.9	1.20	4.5	0.57	2.2	2,000	137.9
			15	117	96	2.32	8.8	1.09	4.1	2,000	137.9	1.93	7.3	0.91	3.4	2,000	137.9
			10	185	152	3.64	13.8	1.72	6.5	2,000	137.9	3.03	11.5	1.43	5.4	2,000	137.9
	7/16 in 11.1 mm	D	8	-	178	-	-	-	-	-	-	3.55	13.4	1.67	6.3	2,000	137.9
			77	23	19	0.57	2.2	0.4	1.5	1,800	124.1	0.48	1.8	0.33	1.2	1,800	124.1
			48	37	30	0.8	3.0	0.6	2.3	1,800	124.1	0.67	2.5	0.50	1.9	1,800	124.1
			24	73	60	1.7	6.4	1.2	4.5	1,800	124.1	1.42	5.4	1.00	3.80	1,800	124.1
			15	117	96	2.8	10.6	2	7.6	1,800	124.1	2.33	8.8	1.67	6.30	1,800	124.1
	5/8 in 15.9 mm	E	10	185	152	4.4	16.7	3.1	11.7	1,800	124.1	3.67	13.9	2.58	9.80	1,800	124.1
			8	-	178	-	-	-	-	-	-	4.30	16.3	3.02	11.40	1,800	124.1
			48	37	30	1.8	6.8	1.4	5.31	925	63.8	1.50	5.7	1.2	4.4	925	63.8
			24	73	60	3.8	14.4	3.1	1.7	925	63.8	3.17	12	2.6	9.8	925	63.8
			15	117	96	6.2	23.5	5.1	19.3	925	63.8	5.17	19.6	4.3	16.6	925	63.8
	1-1/16 in 27 mm	F	10	185	152	9.4	35.6	7.7	29.1	925	63.8	7.83	29.6	6.4	24.3	925	63.8
			8	-	178	-	-	-	-	-	-	9.17	34.7	7.5	28.5	925	63.8
			48	37	30	6.1	23.1	5.5	20.8	350	24.1	5.08	19.2	4.6	17.3	350	24.1
			24	73	60	12.3	46.6	11.2	42.4	350	24.1	10.25	38.8	9.3	35.3	350	24.1
			15	117	96	19.4	73.4	18.1	68.5	350	24.1	16.17	61.2	15.1	57.1	350	24.1
10	185	152	30.0	113.6	29.0	109.8	200	13.8	25.00	94.6	24.2	91.5	200	13.8			
8	-	178	-	-	-	-	-	-	-	29.28	110.8	28.3	107.1	200	13.8		

Capacities shown are for simplex models. Double capacity for duplex models.
Certain options may slightly alter the capacity or pressure ratings shown above.

mROY® Model B - Metallic Liquid Ends

mRoy Model	Plunger		Gear Ratio Code	Stroke/Minute		Capacity/Pressure @ 60 hz 1725 RPM						Capacity/Pressure @ 50 hz 1425 RPM					
	Diameter	Code		60 hz 1725 rpm	50 hz 1425 rpm	Ratings at 100 psi/7 bar		Capacity at Max pressure				Ratings at 100 psi/7 bar		Capacity at Max pressure			
						gph	l/hr	gph	l/hr	psi	bar	gph	l/hr	gph	l/hr	psi	bar
B	19/32 in 15.1 mm	K	38	48	40	4.7	17.8	3.3	12.5	1,500	103.4	3.92	14.8	2.75	10.4	1,500	103.4
			25	72	60	7	26.5	5.6	21.2	1,500	103.4	5.83	22.1	4.67	17.7	1,500	103.4
			19	96	80	9.5	36	7.1	26.9	1,500	103.4	7.92	30	5.92	22.4	1,500	103.4
			12	144	120	13.3	50.3	11.4	43.1	1,500	103.4	11.08	41.9	9.50	36	1,500	103.4
			10	-	148	-	-	-	-	-	1,500	103.4	13.67	51.7	11.72	44.3	1,500
	7/8 in 22.2 mm	L	38	48	40	10	37.9	4.7	17.8	1,000	69	8.33	31.5	3.92	14.8	1,000	69
			25	72	60	16	60.6	11	41.6	1,000	69	13.33	50.5	9.17	34.7	1,000	69
			19	96	80	21	79.5	16	60.6	1,000	69	17.5	66.2	13.33	50.5	1,000	69
			12	144	120	30.4	115.1	25.6	96.9	1,000	69	25.33	95.9	21.33	80.7	1,000	69
			10	-	148	-	-	-	-	-	1,000	69	31.24	118.2	26.31	99.6	1,000
	1-7/16 in 36.5 mm	R	38	48	40	27	102.2	21	79.5	400	27.6	22.5	85.2	17.50	66.2	400	27.6
			25	72	60	42	159	36	136.3	400	27.6	35	132.5	30.00	113.6	400	27.6
			19	96	80	57	215.7	51	193	400	27.6	47.5	179.8	42.50	160.9	400	27.6
			12	144	120	85	321.7	79	299	400	27.6	70.83	268.1	65.83	249.2	400	27.6
			10	-	148	-	-	-	-	-	400	27.6	87.357	330.6	81.19	307.3	400

Capacities shown are for simplex. Double capacity for duplex
Certain options may slightly alter the capacity or pressure ratings shown above.

General Specifications

mROY® Model A - Plastic Liquid Ends

mRoy Model	Plunger		Gear Ratio Code	Stroke/Minute		Capacity/Pressure @ 60 hz 1725 RPM						Capacity/Pressure @ 50 hz 1425 RPM							
						Ratings at 100 psi/7 bar		Capacity at Max pressure				Ratings at 100 psi/7 bar		Capacity at Max pressure					
	Diameter	Code		60 hz	50 hz	Capacity		Max Pressure		gph	l/hr	psi	bar	gph	l/hr	Capacity		Max Pressure	
				1725 rpm	1425 rpm	gph	l/hr	gph	l/hr							psi	bar	gph	l/hr
A	3/8 in 9.5 mm	C	77	23	19	0.32	1.2	0.28	1.1	150	10.3	0.27	1	0.23	0.9	150	10.3		
			48	37	30	0.68	2.6	0.62	2.3	150	10.3	0.57	2.2	0.52	2	150	10.3		
			24	73	60	1.35	5.1	1.30	4.9	150	10.3	1.13	4.3	1.08	4.1	150	10.3		
			15	117	96	2.20	8.3	2.10	7.9	150	10.3	1.83	6.9	1.75	6.6	150	10.3		
	7/16 in 11.1 mm	D	77	23	19	0.5	1.9	0.45	1.7	150	10.3	0.42	1.6	0.38	1.4	150	10.3		
			48	37	30	0.7	2.6	0.65	2.5	150	10.3	0.58	2.2	0.54	2	150	10.3		
			24	73	60	1.5	5.7	1.4	5.3	150	10.3	1.25	4.7	1.17	4.40	150	10.3		
			15	117	96	2.5	9.5	2.4	9.1	150	10.3	2.08	7.9	2.00	7.60	150	10.3		
	5/8 in 15.9 mm	E	48	37	30	1.6	6.1	1.5	5.7	150	10.3	1.33	5	1.3	4.7	150	10.3		
			24	73	60	3.5	13.2	3.4	12.9	150	10.3	2.92	11.1	2.8	10.7	150	10.3		
			15	117	96	5.6	21.2	5.5	20.8	150	10.3	4.67	17.7	4.6	17.3	150	10.3		
	1-1/16 in 27 mm	F	48	37	30	5.7	21.6	5.6	21.2	150	10.3	4.75	18	4.7	17.7	150	10.3		
			24	73	60	11.3	42.8	11.2	42.4	150	10.3	9.42	35.7	9.3	35.3	150	10.3		
			15	117	96	18.1	68.5	18.0	68.1	150	10.3	15.08	57.1	15.0	56.8	150	10.3		

Includes PVC, PVDF liquid ends, and liquid ends for fluoride applications
Capacities shown are for simplex. Double capacity for duplex

Certain options may slightly alter the capacity or pressure ratings shown above.®

mROY Model B - Plastic Liquid Ends

mRoy Model	Plunger		Gear Ratio Code	Stroke/Minute		Capacity/Pressure @ 60 hz 1725 RPM						Capacity/Pressure @ 50 hz 1425 RPM							
						Ratings at 100 psi/7 bar		Capacity at Max pressure				Ratings at 100 psi/7 bar		Capacity at Max pressure					
	Diameter	Code		60 hz	50 hz	Capacity		Max Pressure		gph	l/hr	psi	bar	gph	l/hr	Capacity		Max Pressure	
				1725 rpm	1425 rpm	gph	l/hr	gph	l/hr							psi	bar	gph	l/hr
B	7/8 in 22.2 mm	L	38	48	40	10.0	37.9	9.7	36.7	150	10.3	8.33	31.5	8.1	30.6	150	10.3		
			25	72	60	16.0	60.6	15.7	59.4	150	10.3	13.33	50.5	13.1	49.5	150	10.3		
			19	96	80	21.0	79.5	20.7	78.3	150	10.3	17.50	66.2	17.3	65.3	150	10.3		
			12	144	120	30.4	115.1	30.1	113.9	150	10.3	25.33	95.9	25.1	94.9	150	10.3		
			10	-	148	-	-	-	-	150	10.3	31.24	118.2	30.93	117.1	150	10.3		
	1-7/16 in 36.5 mm	R	38	48	40	27.0	102.2	26.0	98.4	150	10.3	22.50	85.2	21.7	82.0	150	10.3		
			25	72	60	42.0	159	41.0	155.2	150	10.3	35.00	132.5	34.2	129.3	150	10.3		
			19	96	80	57.0	215.7	56.0	212	150	10.3	47.50	179.8	46.7	176.6	150	10.3		
			12	144	120	85.0	321.7	84.0	317.9	150	10.3	70.83	268.1	70.0	265.0	150	10.3		
			10	-	148	-	-	-	-	150	10.3	87.36	330.6	86.33	326.8	150	10.3		

Includes PVC, PVDF liquid ends, and liquid ends for fluoride applications
Capacities shown are for simplex. Double capacity for duplex
Certain options may slightly alter the capacity or pressure ratings shown above.

Power Requirements

mRoy® Frame		A				B							
Plunger Code		C,D,E,F				K		L		R			
		<1,000 psi/67 bar		>1,000 psi/67 bar		<400 psi/28 bar		>400 psi/28 bar		<100 psi/7 bar		>100 psi/7 bar	
1 Ph	Simplex	1/4 HP (0.18 kW)	3/4 HP (0.55 kW)	1 HP (0.75 kW)	3/4 HP (0.55 kW)	1 HP (0.75 kW)	1 HP (0.75 kW)	1 HP (0.75 kW)	1 HP (0.75 kW)	1 HP (0.75 kW)	1 HP (0.75 kW)	1 HP (0.75 kW)	1 HP (0.75 kW)
	Duplex	1/3 HP (0.25 kW)	1 HP (0.75 kW)	1 HP (0.75 kW)	1 HP (0.75 kW)	1 HP (0.75 kW)	1 HP (0.75 kW)	1 HP (0.75 kW)	1 HP (0.75 kW)	1 HP (0.75 kW)	1 HP (0.75 kW)	1 HP (0.75 kW)	1 HP (0.75 kW)
3 Ph	Simplex	1/4 HP (0.18 kW)	1/2 HP (0.37 kW)	3/4 HP (0.55 kW)	1/2 HP (0.37 kW)	3/4 HP (0.55 kW)	3/4 HP (0.55 kW)	3/4 HP (0.55 kW)	3/4 HP (0.55 kW)	3/4 HP (0.55 kW)	3/4 HP (0.55 kW)	3/4 HP (0.55 kW)	3/4 HP (0.55 kW)
	Duplex	1/3 HP (0.25 kW)	3/4 HP (0.55 kW)	1 HP (0.75 kW)	3/4 HP (0.55 kW)	1 HP (0.75 kW)	1 HP (0.75 kW)	1 HP (0.75 kW)	1 HP (0.75 kW)	1 HP (0.75 kW)	1 HP (0.75 kW)	1 HP (0.75 kW)	1 HP (0.75 kW)

The high viscosity option limits the pump to 350 psi (24 bar)

Plunger Size	Plunger Code	Gear Ratio Code	Strokes per Minute		With High Viscosity Option - Max Fluid Viscosity at Typical Conditions (Centipoise)	Standard pump without High Viscosity Option - Viscosity at Typical Conditions (Centipoise)
			60 hz	50 hz		
3/8 in. 9.5 mm	C	77	23	19	-	2,400
		48	37	30	-	1,460
		24	73	60	-	460
		15	117	96	-	250
		10	185	152	-	100
		8	-	178	-	100
7/16 in. 11 mm	D	77	23	19	12,200	2,400
		48	37	30	7,500	1,460
		24	73	60	4,000	460
		15	117	96	2,000	250
		10	185	152	350	100
		8	-	178	350	100
5/8 in. 16 mm	E	48	37	30	5,000	550
		24	73	60	2,500	220
		15	117	96	1,250	120
		10	185	152	350	80
		8	-	178	350	80
		48	37	30	1,000	130
1-1/16 in. 27 mm	F	24	73	60	500	60
		15	117	96	300	30
		10	185	152	120	25
		8	-	178	120	25
		38	48	40	-	130
		25	72	60	-	84
19/32 in. 15.1 mm	K	19	96	80	-	59
		12	144	120	-	39
		10	-	148	-	39
		38	48	40	-	325
		25	72	60	-	186
		19	96	80	-	143
7/8 in. 22.2 mm	L	12	144	120	-	94
		10	-	148	-	94
		38	48	40	-	107
		25	72	60	-	65
		19	96	80	-	46
		12	144	120	-	28
1-7/16 in. 36.5 mm	R	10	-	148	-	28

Dimensions

Model A

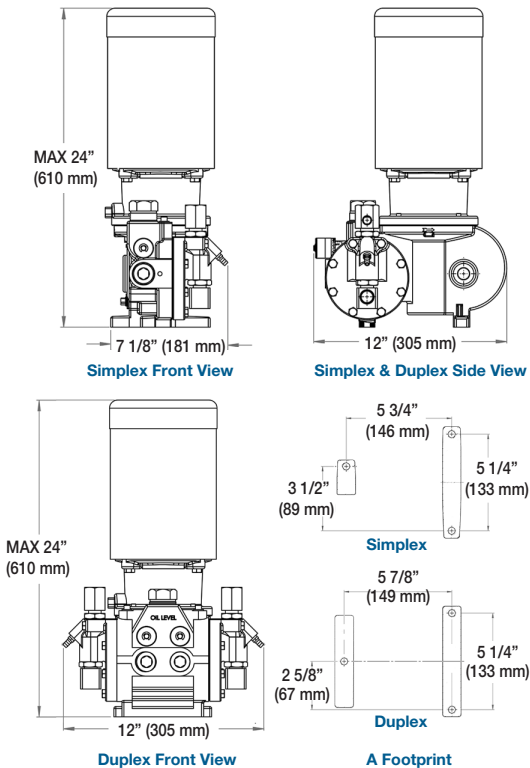

Model B

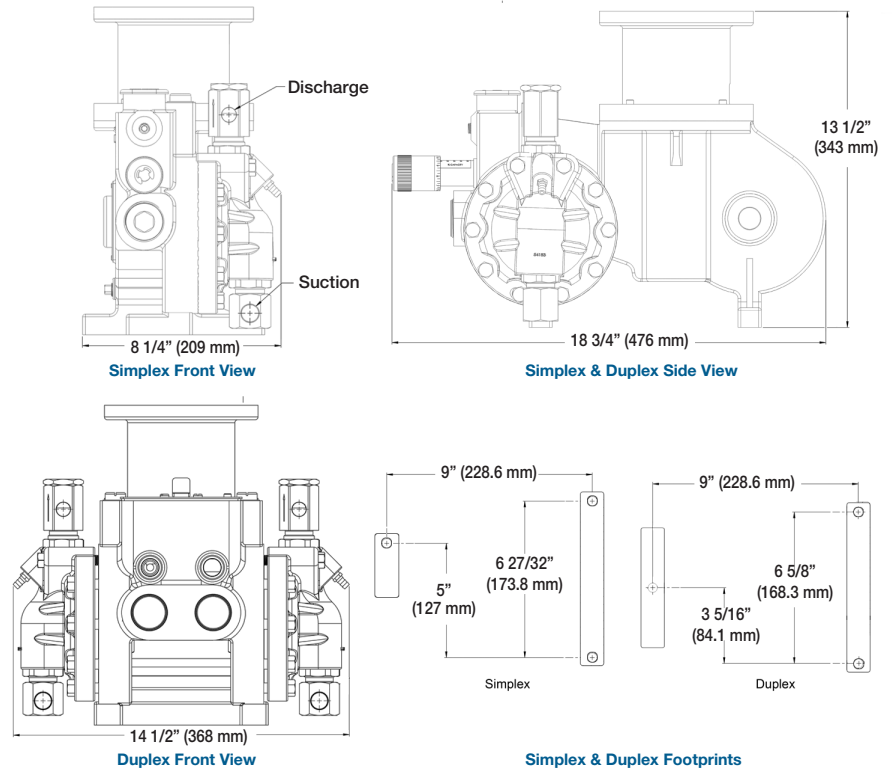

Dimensions are provided for pump envelope estimates with basic options. Drawings are available for the exact configuration required.

Example Code: **MRA** **1** **1** **E** **10** **S1** **A** **P** **P** **N** **S** **4** **N** Extended code for less common options

Frame/Range

MRA
MRB

Number of Heads

1	Simplex
2	Duplex

Liquid End Material

1	316L SS
2	PVC
5	Alloy 20
6	Hast C
7	PVDF
8	Fluoride

Plunger Diameter

MRA Range

C	3/8" (9.5 mm)
D	7/16" (11.1 mm)
E	5/8" (15.9 mm)
F	1 1/16" (27 mm)

MRB Range

K	19/32" (15.1 mm)
L	7/8" (22.2 mm)
R	1 7/16" (36.5 mm)

Gear Ratio Code

Strokes per minute
(60 Hz - 1725 rpm)

MRA Range

77	23
48	37
24	73
15	117
10	185
08	N/A

Strokes per minute
(50 Hz - 1425 rpm)

77	19
48	30
24	60
15	96
10	152
08	178

Strokes per minute
(60 Hz - 1725 rpm)

MRB Range

38	48
28	72
19	96
12	144
10	N/A

Strokes per minute
(50 Hz - 1425 rpm)

38	40
28	60
19	80
12	120
10	148

Motor or IEC/NEMA Mount

There are many options based on power and installation conditions. Your local representative can help select the proper option.

Type Motor Mount

C	Close coupled
A	API Flange with flexible coupling

Base

N	None
Y	Yes
V	VSD Drive

Diaphragm Rupture Detection

N	None
3	Double diaphragm with pressure gauge (not available on plastic ends w/plunger size C and D)
4	Double diaphragm with pressure gauge and NEMA 4 switch
5	Double diaphragm with pressure gauge and explosion proof switch
6	Double diaphragm with intermediate fluid and no probe
7	Double diaphragm with intermediate fluid and probe

Capacity Control

N	Standard aluminum manual micrometer
S	Stainless steel manual micrometer
L	Stainless steel locking manual micrometer (API 675)
W	ACC NEMA 4
E	ACC Ex proof
P	Pneumatic actuator

O Ring Options

N	Standard - Typically Viton
E	EPDM
T	Teflex

Discharge Connections

Suction Connections

Same code used for suction and discharge

Metallic Liquid Ends - Horizontal Connections

P	NPT - Female
---	--------------

Flange - Metallic Liquid Ends

A	ANSI 1/2 in. with raised face, thread, 150 Class
B	ANSI 1/2 in. with raised face, thread, 300 Class
C	ANSI 1/2 in. with raised face, thread, 600 Class
D	ANSI 1/2 in. with raised face, socket weld, 150 Class
E	ANSI 1/2 in. with raised face, socket weld, 300 Class
F	ANSI 1/2 in. with raised face, socket weld, 600 Class

Plastic Liquid Ends - Vertical Connections

P	NPT - Male
---	------------

Flange - Plastic Liquid Ends

P	NPT - Male
1	ANSI 1/2 in. with raised face, thread, 150 Class

mROY® XA & XB

DOSING PUMPS

Maximum flow rate: XA = 66 l/h - XB = 310 l/h

Maximum pressure: XA = 138 bar - XB = 105 bar

Hydraulically actuated diaphragm

Technical characteristics

- Flow rate up to 66 l/h for XA and 310 l/h for XB
- Pressure up to 138 bar for XA and 105 bar for XB
- Maximum temperature of pumped liquid:
 - +90 °C for metallic liquid end
 - +50 °C for plastic liquid end
- Adjustment of flow rate while running or stopped: from 0 to 100%
- Accuracy: $\pm 1\%$ of rated flow from 10% to 100% stroke
- Oil bath lubricated
- Cast iron housing
- Internal safety valve
- For pressures between 10 bar and the maximum discharge pressure of the pump, capacities will decrease by approx. 2% for every 10 bar increase. Accuracy is not affected
- Maximum suction pressure condition:
 - 35 bar: for plungers $\varnothing 11.1$ (XA) and $\varnothing 15.9$ (XB)
 - 17.5 bar: for plungers $\varnothing 15.9$ (XA) and $\varnothing 22.2$ (XB)
 - 9 bar: for plunger $\varnothing 22.2$ (XA)
 - 6 bar: for plungers $\varnothing 27$ (XA) and $\varnothing 36.5$ (XB)
- Working life of the diaphragm can exceed 20,000 hours depending on the pumped fluid, working conditions and installation
- Compact duplex version, with 2 heads of identical or different performance and construction
- Can comply with API 675
- Explosion-proof version is in accordance with ATEX Certification: 2G Ex 4 II C T4 Gb X (plastic liquid end, please consult us)

Electrical characteristics of motors

Standard motor data:

- Supply: 230/400 V, 3-phase, 50 Hz or 260/460 V, 3-phase, 60 Hz
- IM V1 mounting, FF130 flange, 14x30 mm shaft for XA and FF165 flange, 19x40 mm or 24x50 mm shaft for XB
- Protection: IP 55, tropicalized (90% of humidity)
- Insulation: class F
- Ambient temperature: -10°C to +50°C
- Motor speed: 1500 or 3000 rpm for XA and 1000 or 1500 rpm for XB
- Motors are in accordance with national and international standards
- Special or specific motors on request



Liquid end construction

	CONSTRUCTION	
COMPONENTS	PVC ⁽¹⁾	316L ⁽²⁾
Liquid end body	PVC	316L
Check valve cartridge	PVC	316L
Seats	PVC	316L
Balls	Glass	316L
Contour plate	PVC	316L
Diaphragm	PTFE	PTFE
Discharge ball spring	Hast. C	316L
Seals	Viton	Viton

⁽¹⁾ Pressure is limited to 10 bar at 20°C and pressure derated 1.1 bar / 5°C. Maximum operating temperature: 50°C

⁽²⁾ Milton Roy Europe keeps an interchangeability table for national and international standards (AFNOR, DIN, ASTM, BS, etc).

OTHER LIQUID END MATERIAL

- "**H₂SO₄ CONCENTRATED**" version: 316L S.S. liquid end with check valve cartridge and seats in 904L; balls and spring in Hastelloy C
- "**904L**" version: 904L liquid end with balls and spring in Hastelloy C
- **Other version on request:** consult us

Options

- Flexible coupling (API 675)
- Double diaphragm with rupture detector
- Automatic flow rate adjustment: electronic servomotor, explosion-proof servomotor, pneumatic servomotor, frequency variation
- Flange connections
- Stroke counter

Performances

mROY XA - Plastic and Metallic liquid ends

Flow at 3 bar (l/h)	Plastic liquid end		316L stainless steel liquid end		Stroke speed (spm)	Plunger Ø (mm)	Diaphragm Ø (mm)	Swept volume (cm ³)	3-phase motor (kW - rpm)
	Flow at max. pressure (l/h)	Max. pressure (barg)	Flow at max. pressure (l/h)	Max. pressure (barg)					
2.6	2.5	10	1.9	123	29	11.1	71	1.74	0.25 - 1500
5.5	-	-	4	123	58	11.1	71	1.74	0.37 - 3000
5.5	5.3	10	4.8	59	29	15.9	101	3.57	0.25 - 1500
10	9	10	8	123	112	11.1	71	1.74	0.25 - 1500
22	21	10	19	59	112	15.9	101	3.57	0.25 - 1500
44	43	10	39	31	112	22.2	101	6.96	0.25 - 1500
66	65	10	64	21	112	27	101	10.3	0.25 - 1500

mROY XB - Plastic liquid end

Flow at 3 bar (l/h)	Flow at max. pressure (l/h)	Max. pressure (bar)	Stroke speed (spm)	Plunger Ø (mm)	Diaphragm Ø (mm)	Swept volume (cm ³)	3-phase motor (kW - rpm)
30	29	10	36	22.2	132	13.93	0.55 - 1000
46	45	10	56	22.2	132	13.93	0.55 - 1500
74	73	10	90	22.2	132	13.93	0.55 - 1000
80	79	10	36	36.5	132	37.66	0.55 - 1000
114	113	10	140 ⁽¹⁾	22.2	132	13.93	0.75 - 1500
124	123	10	56	36.5	132	37.66	0.55 - 1500
200	199	10	90	36.5	132	37.66	0.55 - 1000
310	309	10	140 ⁽¹⁾	36.5	132	37.66	0.75 - 1500

mROY XB - Metallic liquid end

Flow at 3 bar (l/h)	Flow at max. pressure (l/h)	Max. pressure (bar)	Stroke speed (spm)	Plunger Ø (mm)	Diaphragm Ø (mm)	Swept volume (cm ³)	3-phase motor (kW - rpm)
14	11	105	36	15	86	6.36	0.55 - 1000
21	17	105	56	15	86	6.36	0.75 - 1500
30	28	49	36	22.2	132	13.93	0.55 - 1000
30	26	100	36	22.2	132	13.93	0.75 - 1000
34	27	105	90	15	86	6.36	0.55 - 1000
46	40	100	56	22.2	132	13.93	0.75 - 1500
53	43	105	140 ⁽¹⁾	15	86	6.36	0.75 - 1500
74	70	49	90	22.2	132	13.93	0.55 - 1000
74	65	100	90	22.2	132	13.93	0.75 - 1000
80	78	14	36	36.5	132	37.66	0.55 - 1000
80	77	28	36	36.5	132	37.66	0.75 - 1000
114	109	49	140 ⁽¹⁾	22.2	132	13.93	0.75 - 1500
114	103	100	140 ⁽¹⁾	22.2	132	13.93	1.10 - 1500
124	120	28	56	36.5	132	37.66	0.75 - 1500
200	196	14	90	36.5	132	37.66	0.55 - 1000
200	193	28	90	36.5	132	37.66	0.75 - 1000
310	304	14	140 ⁽¹⁾	36.5	132	37.66	0.75 - 1500
310	299	28	140 ⁽¹⁾	36.5	132	37.66	1.10 - 1500

⁽¹⁾ Do not use with 60 Hz motor

Dimensions mROY XA (in mm)

Simplex version - Metallic liquid end

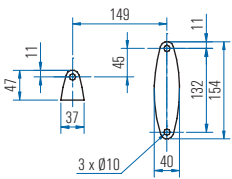
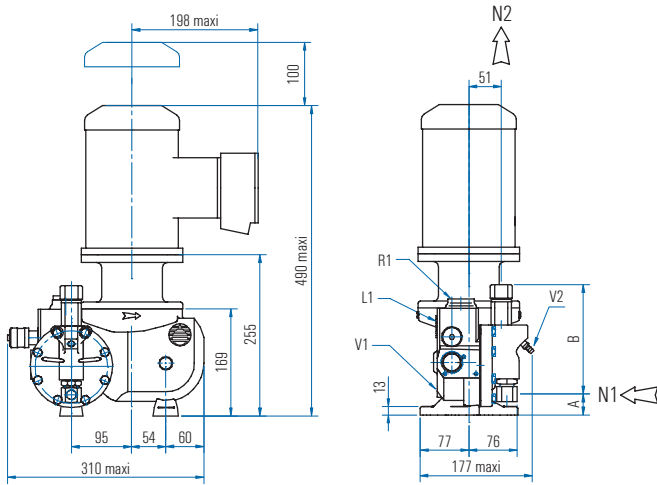

MODELS	DIMENSIONS	CONNECTIONS
5,5 l/h ⁽¹⁾ - 22 l/h 44 l/h - 66 l/h	A = 33 B = 173	Suction: 3/8" GAS F Discharge: 3/8" GAS F
2,6 l/h - 5,5 l/h ⁽²⁾ 10 l/h	A = 41 B = 163	Suction: 3/8" GAS F Discharge: 3/8" GAS F

⁽¹⁾ 5,5 l/h at 59 bar - ⁽²⁾ 5,5 l/h at 123 bar

Simplex version - Plastic liquid end

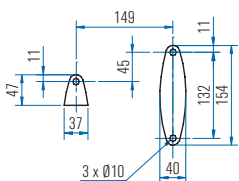
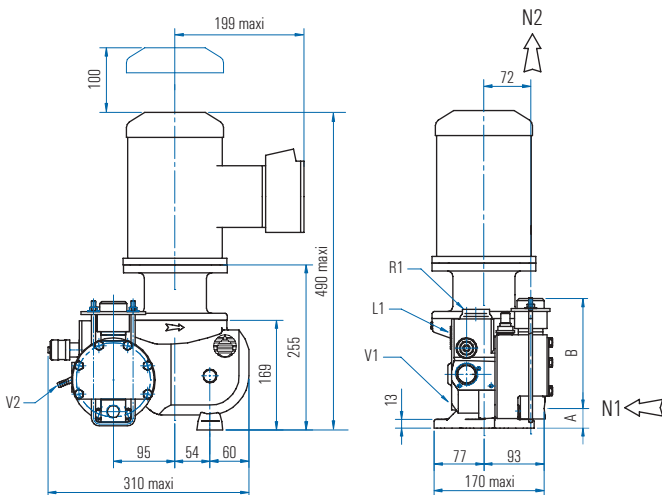

MODELS	DIMENSIONS	CONNECTIONS
22 l/h - 44 l/h 66 l/h	A = 28 B = 170	Suction: 1/2" GAS F Discharge: 3/8" GAS F
2,6 l/h - 5,5 l/h 10 l/h	A = 25 B = 177	Suction: 1/2" GAS F Discharge: 3/8" GAS F

N1: Suction
N2: Discharge
V2: Oil drain
V1: Drain
L1: Oil level
R1: Oil fill

Dimensions mROY XB (in mm)

Simplex version - Metallic liquid end

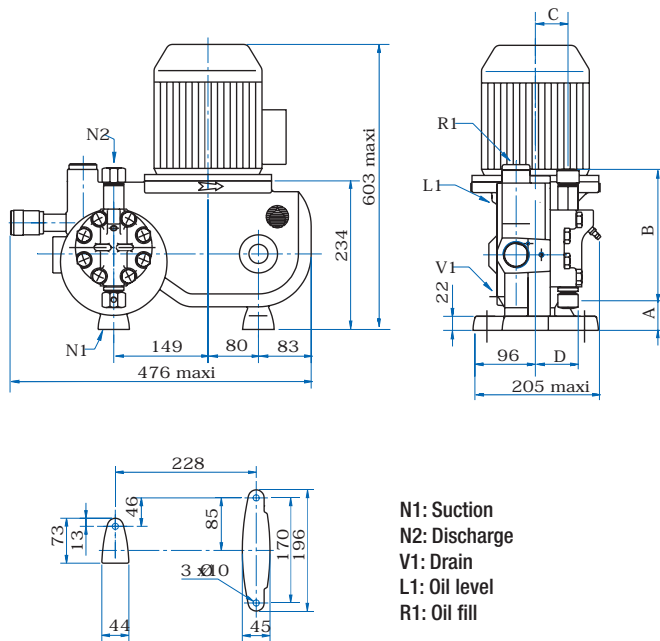

Simplex version - Plastic liquid end

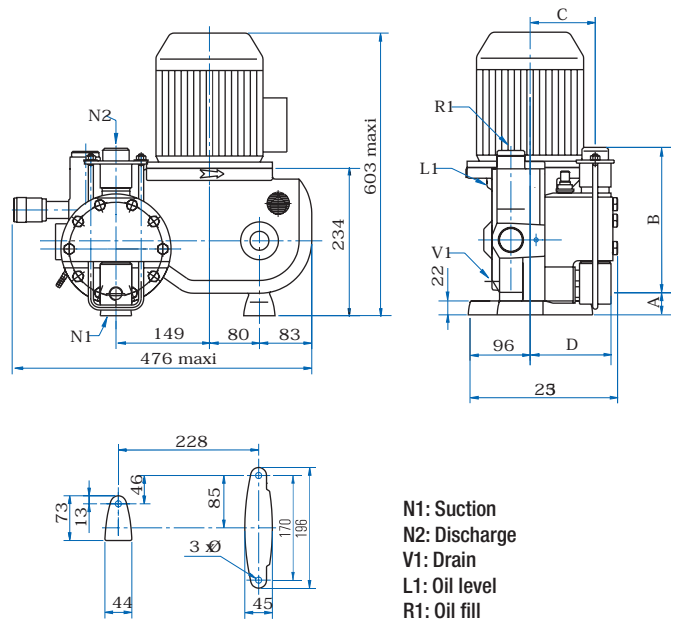

MODELS	DIMENSIONS	CONNECTIONS
30 l/h - 46 l/h 74 l/h - 80 l/h - 114 l/h 124 l/h - 200 l/h - 310 l/h	A = 22 B = 233 C = 56 D = 97	Suction: 1/2" GAS F Discharge: 3/8" GAS F
14 l/h - 21 l/h 34 l/h - 53 l/h	A = 47 B = 207 C = 52 D = 68	Suction: 3/8" GAS F Discharge: 3/8" GAS F

MODELS	DIMENSIONS	CONNECTIONS
30 l/h - 46 l/h 74 l/h - 80 l/h - 114 l/h 124 l/h - 200 l/h - 310 l/h	A = 35 B = 231 C = 104 D = 129	Suction: 1/2" GAS F Discharge: 3/8" GAS F

Protection

- As a standard pumps are protected with one coat of AMERON polyurethane paint of 100 microns, yellow RAL 1018
- Other treatment: consult us

Lubrication

- Ambient temperature from -5°C to +90°C:
Oil ISO - CC150 equivalent
- Temperature < -5°C: Consult us
- Quantity: 1 liter for XA and 3 liters for XB

Weight and packing

Models	Net weight (with oil)	Gross weight (with packing)	Packing ⁽¹⁾ (L x W x H)
mROY XA	approx. 25 kg	approx. 30 kg	355 x 355 x 575 mm
mROY XB	approx. 49 kg	approx. 58 kg	515 x 465 x 720 mm

⁽¹⁾ Standard cardboard packing

XT and XW Models

mROY® series model XT and XW metering pumps are controlled-volume, hydraulically-actuated diaphragm pumps that are designed for consistent chemical delivery. Its compact design contains a plunger that reciprocates at a fixed stroke, displacing a fixed volume of hydraulic fluid and thereby actuating a flexible, chemically inert PTFE diaphragm to create the pumping action. Designed to meet global industry standards, models XT and XW provide accurate dosing of a broad spectrum of fluids. Like all mROY® metering pumps, models XT and XW are built to run continually all year long leading to decades of consistent performance.

Applications

Injection of chemicals such as biocides, polymers, scale and corrosion inhibitors, salt and wax inhibitors, process additives and many more for the following areas of application:

- **Chemical and petrochemical processing**
- **Boilers**
- **Oil and gas production**
- **Food**
- **Power generation**

Technical	XT	XW
Max Flow	2.2 gph (8.3 l/hr)	9.2 gph (34.8 l/hr)
Max Pressure	3000 PSI (207 bar)	3000 PSI (207 bar)
Stroke Length	0.75 inches (19 mm)	1.5 inches (38.1 mm)

Temperature Range		
	Ambient	Liquid
Standard	20°F (-6°C) to 120°F (49°C)	-20°F (-29°C) to 200°F (93°C)
Low	-40°F (-40°C) to 120°F (49°C)	-45°F (-43°C) to 200°F (93°C)
High	20°F (-6°C) to 120°F (49°C)	50°F (10°C) to 300°F (149°C)



Features and Benefits

- Hydraulically balanced PTFE diaphragm, designed for 96,000 hours operating life, does not use seals and eliminates plunger packing maintenance.
- Turndown ratios up to 10:1 with constant speed motor
- Steady state accuracy $\pm 1.0\%$ and Repetitive accuracy $\pm 3.0\%$
- Liquid end bleed system makes it easier to commission a new or a newly maintained pump.
- Worm and pinion drive operating in an oil bath lubrication produces a smooth mechanical motion that eliminates wear and tear of mechanical lost motion designs and assures long gear and bearing life.
- Dust-tight cast iron housing provides a rugged enclosure for operation in the harshest plant and field environments.
- Micrometer capacity adjustment enables accurate output flow control.
- Internal hydraulic pressure relief valve automatically protects the pump's hydraulic system from over pressure conditions.
- High-performance, adjustable, cartridge-type check valves provide positive, repeatable sealing on every pump stroke.
- The pump meets standards for API 675.

Capacity/Pressure Tables

0 to 9.2 GPH (34.8 L/H) - 3000 PSI (207 BAR) maximum

	Plunger Diameter	Gear Ratio Code	Strokes Per Minute		Metallic Liquid Ends												
					GPH at 2000 psi		GPH at 2500 psi		GPH at 3000 psi		L/hr at 138 BAR		L/hr at 172 BAR		L/hr at 207 BAR		
					60 hz	50 hz	60 hz	50 hz	60 hz	50 hz	60 hz	50 hz	60 hz	50 hz	60 hz	50 hz	
mRoy XT	11/32" 9 mm	77	23	19	0.27	0.23	0.26	0.21	0.24	0.20	1.04	0.87	0.97	0.81	0.90	0.75	Requires 0.37 kW (1/2 HP) motor
		48	37	30	0.44	0.37	0.41	0.34	0.38	0.32	1.67	1.39	1.55	1.29	1.44	1.20	
		24	73	60	0.87	0.73	0.80	0.67	0.74	0.62	3.30	2.75	3.00	2.50	2.80	2.33	
		15	117	96	1.37	1.14	1.27	1.06	1.19	0.99	5.20	4.33	4.80	4.00	4.50	3.75	
		10	185	152	2.2	1.8	2.1	1.7	1.9	1.6	8.3	6.9	7.7	6.4	7.2	6.0	
mRoy XW	1/2" 13 mm	38	48	40	2.8	2.3	2.6	2.2	2.5	2.1	10.6	8.8	10.1	8.4	9.3	7.8	Requires 0.75 kW (1 HP) motor
		25	72	60	4.3	3.6	4.0	3.3	3.8	3.1	16.2	13.5	15.1	12.6	14.2	11.9	
		19	96	80	5.8	4.8	5.4	4.5	5.0	4.2	21.9	18.3	20.4	17.0	18.9	15.8	
		12	144	120	9.2	7.7	8.6	7.2	8.0	6.7	34.8	29.0	32.5	27.1	30.3	25.2	

Actuators and rupture detection require capacity derating per the table on page 3.

Capacity Adjustment Table

mRoy pump capacity must be derated when any of the following options are selected:

- Electronic Capacity Control
- Diaphragm Rupture Detection System

Plunger Diameter	11/32" (9mm)	1/2" (13mm)
Pump Model	XT	XW
Electronic Capacity Control	1.00	1.00
Diaphragm Rupture Detection System	0.95	0.95

Piping Connection Sizes

Model	Suction	Discharge
XT	1/4" NPT Male	1/4" NPT Female
XW	1/2" NPT Female	1/4" NPT Female

Materials of Construction

Liquid End Material	Diaphragm	Head	Valve Body	Seats	Ball	Seals	Contour Plate	Check Valve Springs
316SS	PTFE	316SS	316SS	316SS	316SS	Viton & Buna N	316SS	316SS

Dimensions Dimensions are provided for pump envelope estimates with basic options. Certified prints are available.

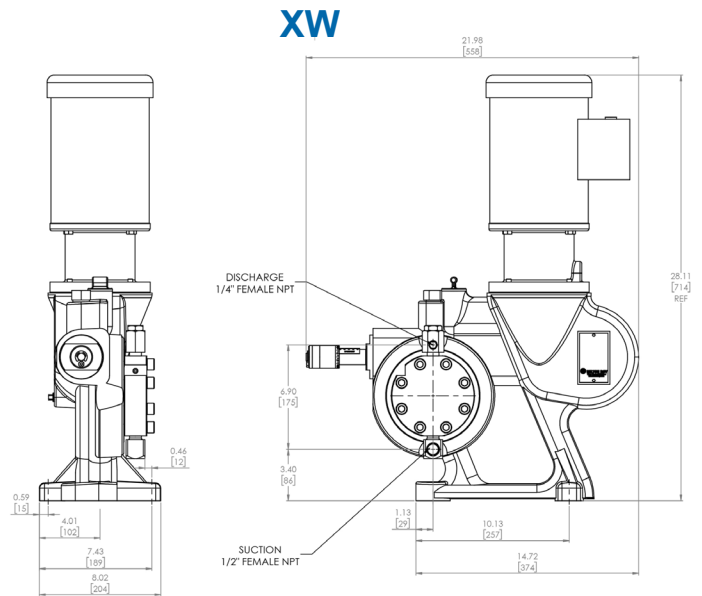
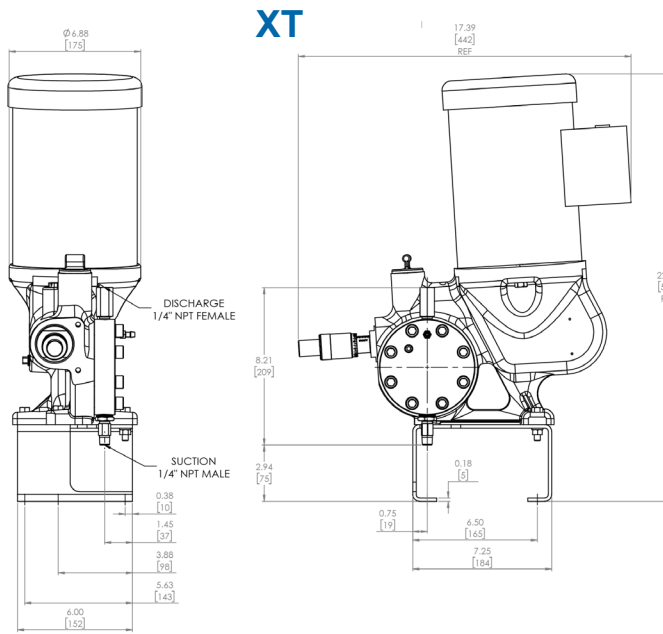

Bolt Hole Dimensions Bolt holes accommodates 5/16" (8mm) diameter bolts.

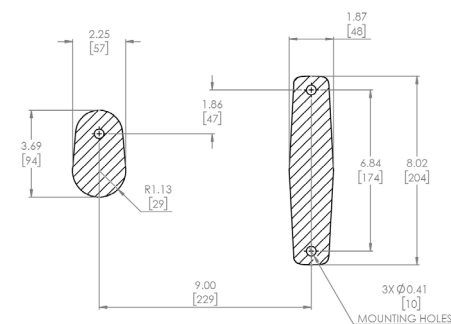
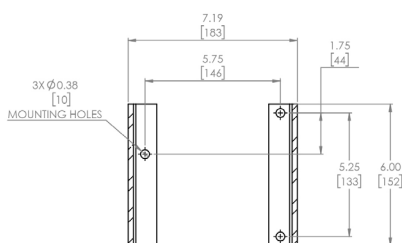

Model Selection Guide for XT

MODEL CODE

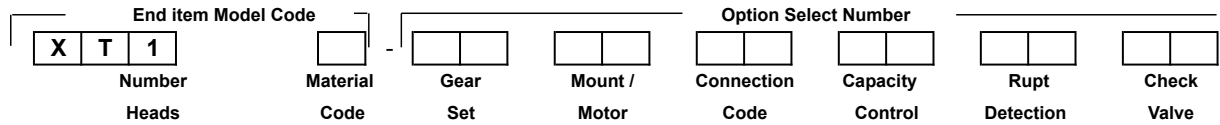

LIQUID END MATERIAL

Code	Description
1	316 SS (Standard)

GEAR SET

Code	Description	1725 rpm	1425 rpm	1140 rpm
77	77:1 Gear Ratio	23 spm	19 spm	14.5 spm
48	48:1 Gear Ratio	37 spm	30 spm	24 spm
24	24:1 Gear Ratio	73 spm	60 spm	47 spm
15	15:1 Gear Ratio	117 spm	96 spm	76 spm
10	9.5:1 Gear Ratio	185 spm	152 spm	120 spm

MOTOR MOUNTS

Motor supplied by Milton Roy

Code	Description
SR	Close Coupled Flange, NEMA 56C (48 Frame) (Standard)
SS	Close Coupled Flange, IEC Frame 71, B5 Flange
FR	API Flange Mount, NEMA 56C
F4	API Flange Mount, NEMA 143TC
FS	API Flange Mount, IEC Frame 71, B5
MD	API Flange Mount IEC Frame 80, B5 Flange
F9	API Flange Mount, IEC Frame 90, B5 Flange

Motor supplied by Others

Code	Description
1X	Close Coupled Flange, NEMA 56C
2X	Close Coupled Flange, IEC Frame 71, B5 Flange
3X	API Flange Mount, NEMA 56C
4X	API Flange Mount, NEMA 143TC
5X	API Flange Mount, IEC Frame 71, B5 Flange
6X	API Flange Mount, IEC Frame 80, B5 Flange
7X	API Flange Mount, IEC Frame 90, B5 Flange

CONNECTIONS

Code	Description
NN	Standard NPT 1/4" NPT Suction, 1/4" Discharge
AA	ANSI 150# RF 1/2" Socket Welded
BB	ANSI 300# RF 1/2" Socket Welded
EE	ANSI 1500# RF 1/2" Socket Welded
11	ANSI 150# RF 1/2" Threaded
33	ANSI 300# RF 1/2" Threaded
66	ANSI 600# RF 1/2" Threaded

CAPACITY CONTROL

Code	Description
M1	Manual Micrometer Knob, 316 SS
AW	ACC NEMA 4 (4-20 mA input) 24VDC; 85V to 260V 1 phase 50/60Hz, -40°C/°F
AE	ACC Ex-Proof (4-20 mA input) 24VDC; 85V to 260V 1 phase 50/60Hz, -40°C/°F

RUPTURE DETECTION

Code	Description
NN	None
C5	Rupture Detection with Base & Gauge
SN	Rupt.Detect w/ Base,Gauge,& NEMA 4 Switch
S7	Rupt.Detect.w/ Base, Gauge, & Ex. Prf Switch

CHECK VALVE

Code	Description
NN	Single Ball Checks (Standard)
22	Double Ball Checks

Model Selection Guide for XW

MODEL CODE

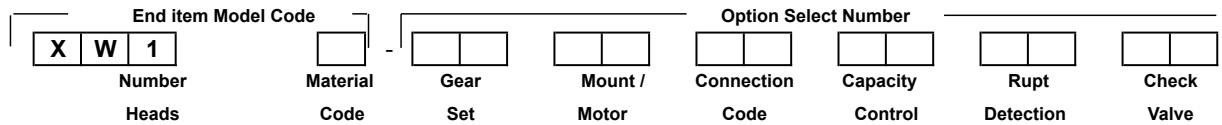

LIQUID END MATERIAL

Code	Description
1	316 SS (Standard)

GEAR SET

Code	Description	1725 rpm	1425 rpm	1140 rpm
38	38:1 Gear Ratio	47 spm	39 spm	31 spm
25	25:1 Gear Ratio	72 spm	60 spm	48 spm
19	19:1 Gear Ratio	95 spm	79 spm	62 spm
12	12:1 Gear Ratio	144 spm	120 spm	95 spm

MOTOR MOUNTS

Motor supplied by Milton Roy

Code	Description
FR	API Flange Mount, NEMA 56C (Standard)
F4	API Flange Mount, NEMA 143TC/145TC
F8	API Flange Mount, IEC Frame 80, B5 Flange
F9	API Flange Mount, IEC Frame 90, B5 Flange

Motor supplied by Others

Code	Description
3X	API Flange Mount, NEMA 56C
4X	API Flange Mount NEMA 143TC / 145 TC
6X	API Flange Mount, IEC Frame 80, B5 Flange
7X	API Flange Mount, IEC Frame 90, B5 Flange

CONNECTIONS

Code	Description
NN	Standard NPT 1/2" NPT Suction, 1/4" NPT Discharge
AA	ANSI 150# RF 1/2" Socket Welded
BB	ANSI 300# RF 1/2" Socket Welded
EE	ANSI 1500# RF 1/2" Socket Welded
11	ANSI 150# RF 1/2" Threaded
33	ANSI 300# RF 1/2" Threaded
66	ANSI 600# RF 1/2" Threaded

CAPACITY CONTROL

Code	Description
M1	Manual Micrometer Knob, 316 SS
AW	ACC NEMA 4 (4-20 mA input) 24VDC; 85V to 260V 1 phase 50/60Hz, -40°C/°F
AE	ACC Ex-Proof (4-20 mA input) 24VDC; 85V to 260V 1 phase 50/60Hz, -40°C/°F

RUPTURE DETECTION

Code	Description
NN	None
C5	Rupture Detection with Base & Gauge
SN	Rupt.Detect w/ Base,Gauge,& NEMA 4 Switch
S7	Rupt.Detect.w/ Base, Gauge, & Ex. Prf Switch

CHECK VALVE

Code	Description
NN	Double Ball Checks (Standard)

About Ingersoll Rand Inc.

Ingersoll Rand Inc. (NYSE:IR), driven by an entrepreneurial spirit and ownership mindset, is dedicated to helping make life better for our employees, customers and communities. Customers lean on us for our technology-driven excellence in mission-critical flow creation and industrial solutions across 40+ respected brands where our products and services excel in the most complex and harsh conditions. Our employees develop customers for life through their daily commitment to expertise, productivity and efficiency. For more information, visit www.IRCO.com.



To learn more about the mRoy® Series metering pumps, contact your local representative or visit miltonroy.com

Leak Detection System Options

The mROY metering pump optional leak detection system monitors the condition of the pump's diaphragm to prevent cross-contamination of the process fluid and the pump's hydraulic system. This optional feature comes with either a pressure gauge or switch that is connected to the pump head between redundant diaphragms. During normal operation, the pressure between the two diaphragms is much lower than the process pressure. If either diaphragm fails, the system senses the process pressure from either fluid while the redundant diaphragm continues to create a seal between the two fluids. When pressure is encountered, the leak detection system indicates the pressure change on a gauge or can activate the pressure switch to stop the pump or sound an alarm. Additional options for connecting a pressure transmitter are available.

Applications

The mROY series diaphragms are extremely durable and feature a design life of 96,000 hours. The leak detection option adds additional security and is ideal for critical dosing applications where toxic, aggressive or environmentally hazardous chemicals are used, or where pumps are remotely mounted and not routinely observed in operation.

Features and Benefits

- The system detects pressure variations and shuts the pump down, safeguarding equipment and protecting process fluids.
- The rupture detection system is available with a gauge or switch design to provide an ideal process configuration.
- The gauge and switch options reduce downtime and costs by protecting against equipment loss.
- The designs reduce the overall pump footprint, providing ultimate protection in tight or confined spaces.

Specifications

- Pressure switches available in NEMA 4 or Explosion Proof enclosures
- Leak detection system capable of operating over the pump's full pressure range
- Industrial process grade pressure gauges

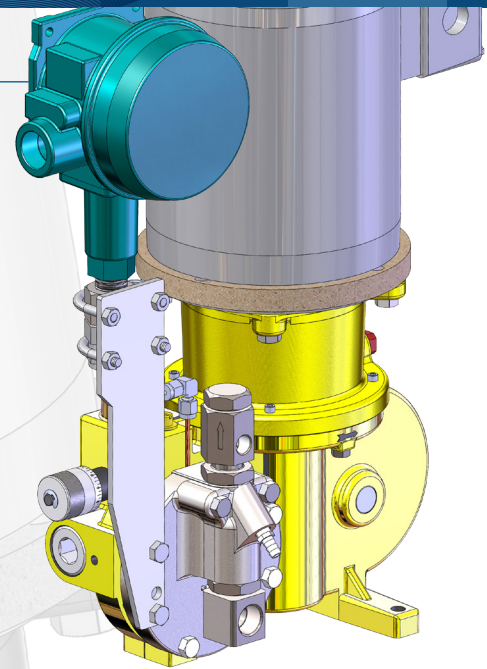

Switch Option

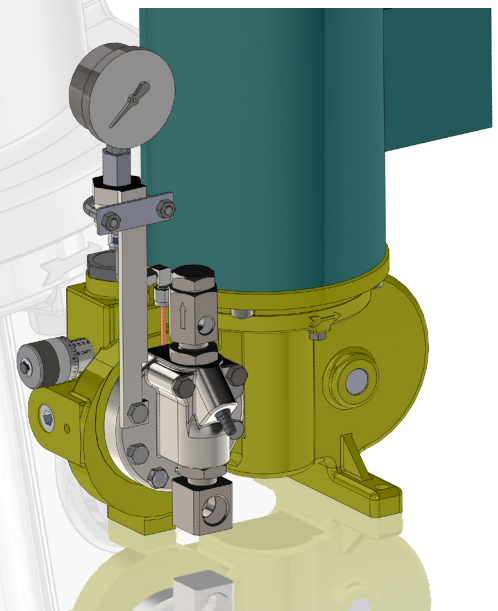

Pressure Gauge Option

**Global mRoy – CS Drawing E & F
Plunger Gauge Only**

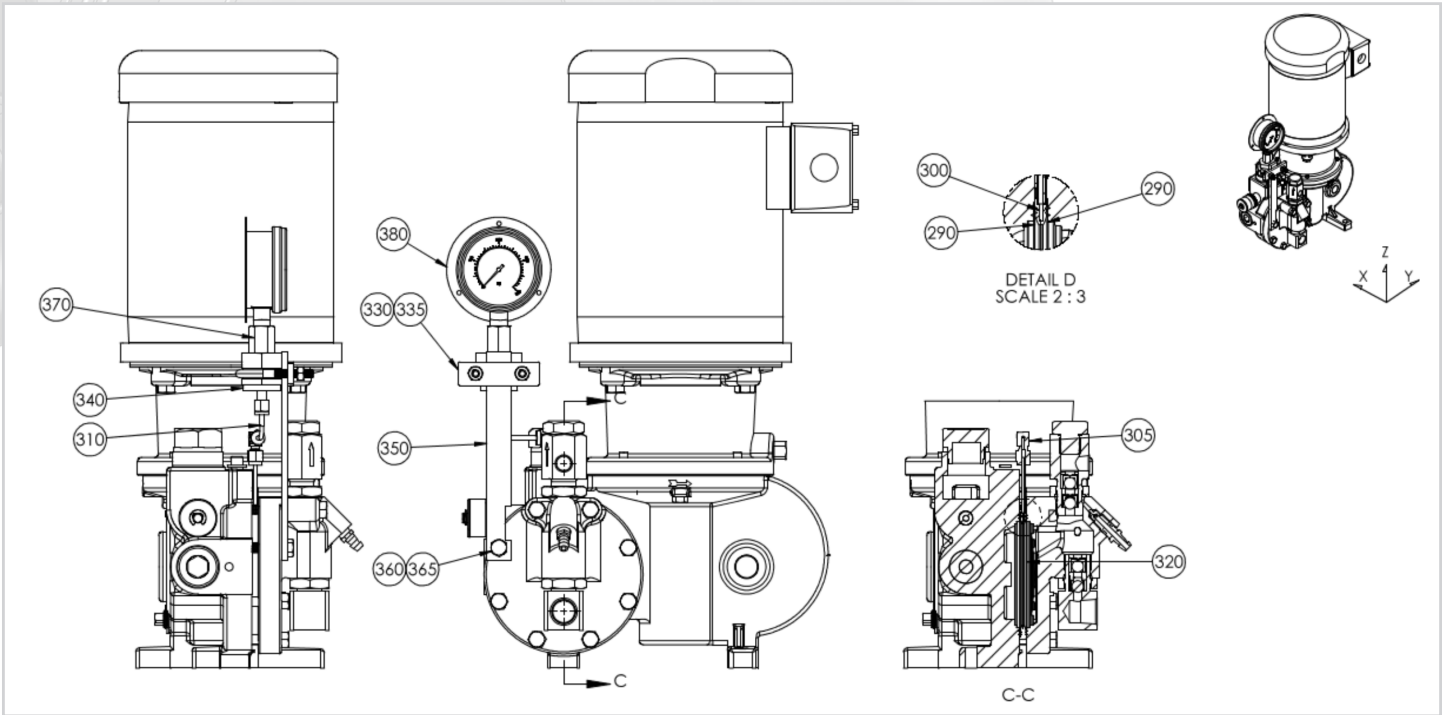

**Global mRoy – CS Drawing E & F
Plunger Switch Only**

